

INSTALLATION AND OPERATION INSTRUCTIONS

BEER DISPENSERS

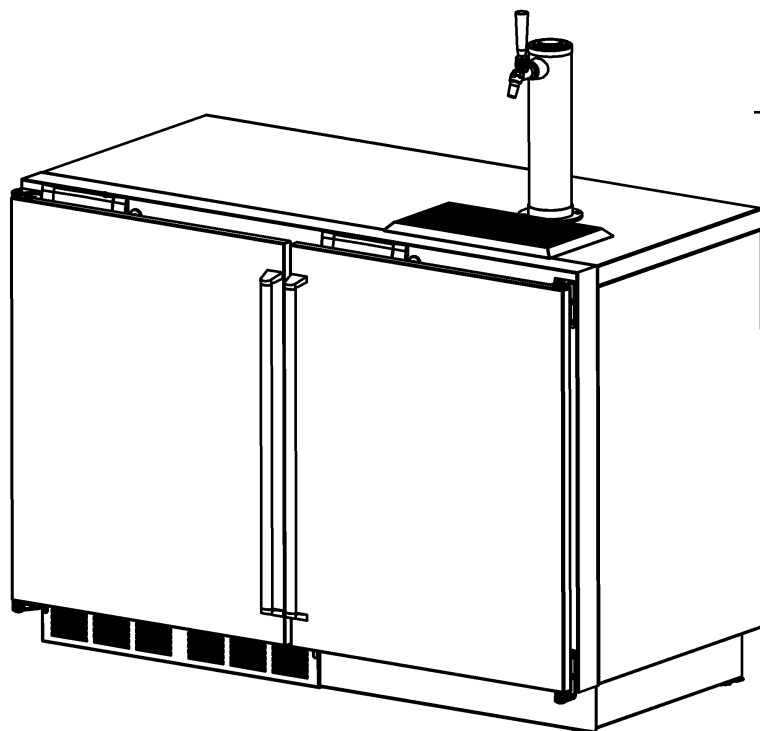

MODEL NOS.

H Series



IMPORTANT INFORMATION

Fill out the enclosed warranty card and mail to the Perlick Corporation to register the warranty. If the card is not returned, the warranty period will begin from the date the equipment is shipped from the factory.

This manual has been prepared to assist you in the installation of your Direct Draw Dispenser and to acquaint you with its operation and maintenance.

We dedicate considerable time to ensure that our products provide the highest level of customer satisfaction. If service is required, your dealer can provide you with a list of qualified service agents. For your own protection, never return merchandise for credit without our approval.

We thank you for selecting a Perlick product and assure you of our continuing interest in your satisfaction.

WARNING: When lifting, the full weight of the cabinet must be supported. Lift from the cabinet base and not from the top. Improper lifting can result in severe damage to the cabinet.

Table of Contents

Cabinet Specifications.....	2
Preparing the Cabinet.....	3
Placing the Cabinet.....	3
Cleaning the Cabinet.....	4
Cleaning the Condenser.....	4
Temperature Control.....	4
Installing the Dispensing Head.....	5
Connecting the CO ₂ Cylinder.....	6
Replacing a CO ₂ Gas Cylinder.....	7
Handling CO ₂ Gas.....	7
TEMPERATURE	
Beer Temperature.....	7
CLEANING	
Cleaning the Beer Lines.....	8
GENERAL INFORMATION	
Troubleshooting.....	9
Door Switching Instructions.....	10
Tap Mounting Hole Location.....	11
Pouring a Perfect Glass of Beer.....	12
Low Profile Coupler.....	13
Keg Capacity and Location.....	14



Sizes and Specifications Beer Dispensers

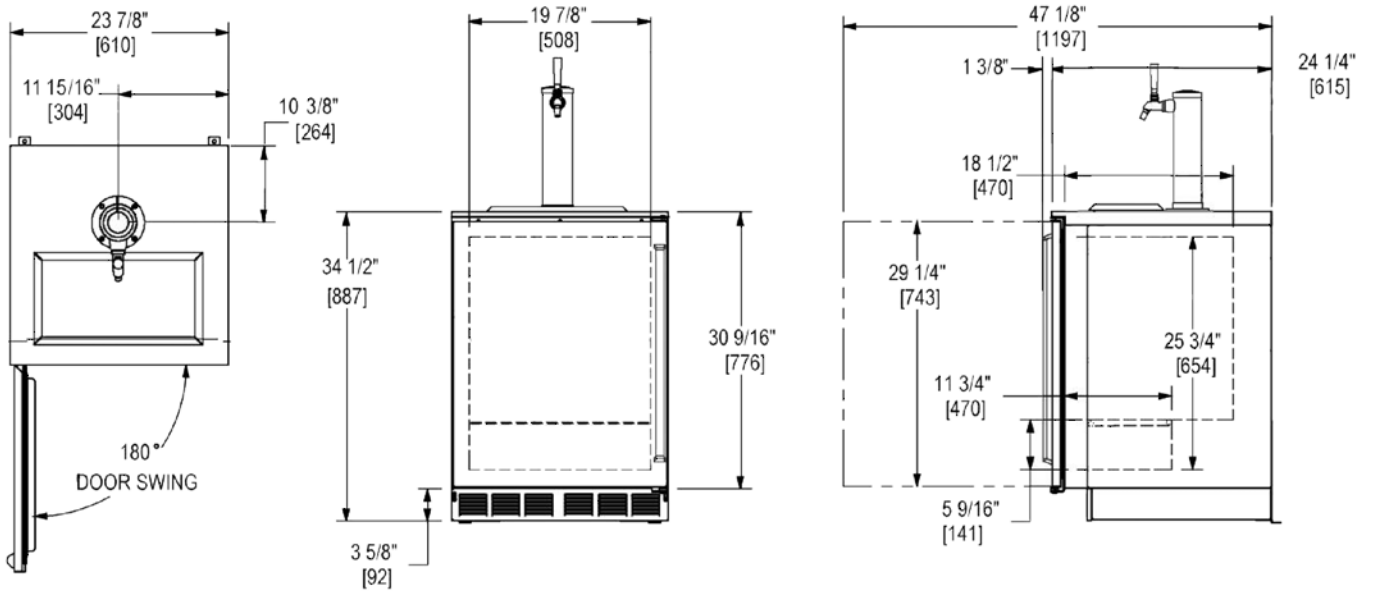
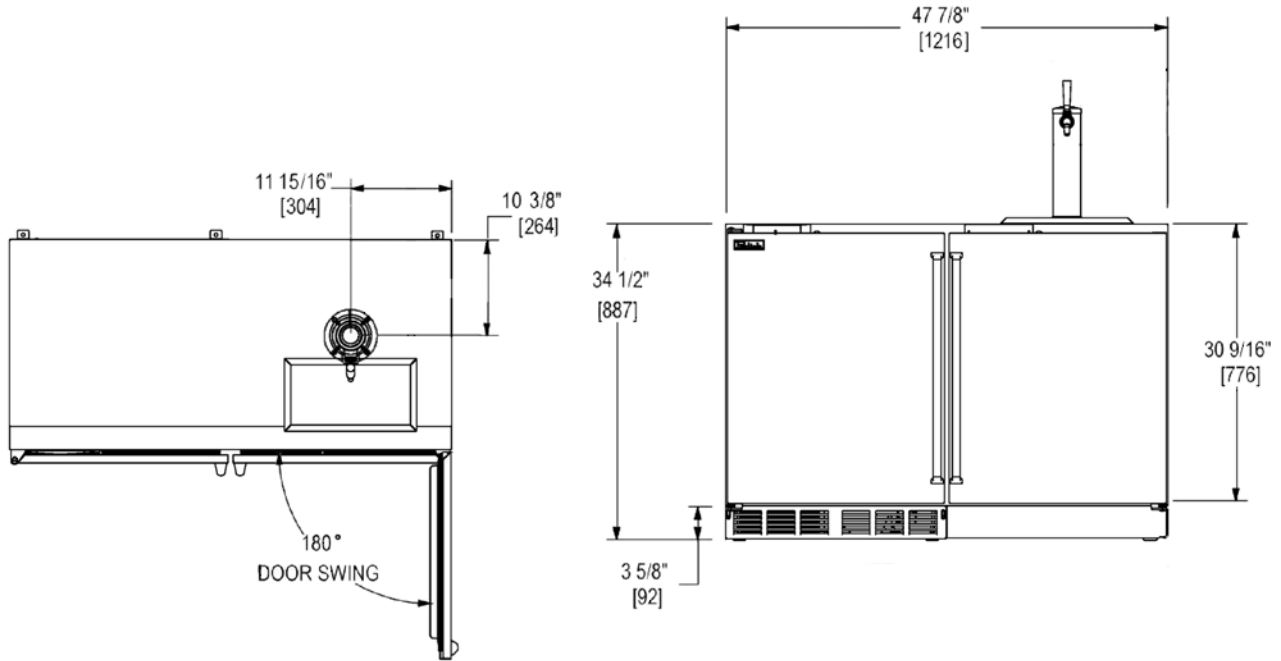

Preparing the Cabinet – Beer Dispensers

Uncrating and Inspection

Remove all crating material before operating. Carefully inspect cabinet for hidden damage. If damage is discovered, file your claim immediately with the transport company. Perlick is not responsible for damage in transit.

Plumbing

No plumbing connections are required. Condensate from the cooling coil is automatically evaporated through a condensate pan located in the condensing unit section.

Electrical

The cabinet must be connected to a separately fused power source (see Electrical Specification Plate) and grounded in accordance with National and Local Electrical Codes.

CAUTION: Do not attempt to operate the equipment on any other power source than that listed on the Electrical Specification Plate.

Placing the Cabinet

To assure maximum performance, fresh air must be allowed to circulate through the machinery compartment. Do not place anything in front of the cabinet that would obstruct air flow at these grilles. Do not place the unit in an unventilated small room.

Cabinet should be leveled front to back and side to side.

Installing Casters or Legs (optional)

Attach casters or legs to the mounting bracket with the lockwashers and 1/4-20 hex head nuts provided. Attach bracket and leg/caster assembly to the side of the cabinet base using the 1/4-20 hex head self-tapping machine screws provided.

Anti-tip (without Legs or Casters)

To prevent the cabinet from tipping forward and to provide a stable installation, the cabinet must be secured in place with an anti-tip device.

A set of metal anti-tip brackets and installation screws (#10-3/4" wood screw) are supplied. These brackets should be attached to the floor, at the back of the cabinet; each bracket located to catch each rear leveling leg when the cabinet is pushed backward into position.

THE ANTI-TIP BRACKETS MUST CATCH EACH OF THE LEVELING LEGS TO HAVE A STABLE AND SAFE INSTALLATION.

Some installation sites might need to be modified to provide a secure surface for attaching the bracket. Refer to the illustration below for anti-tip mounting bracket locations.

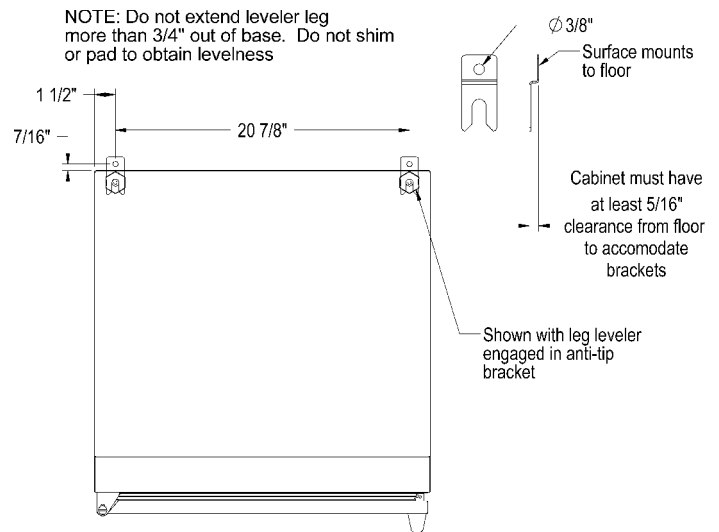

Perlick is committed to continuous improvement. Therefore, we reserve the right to change specifications without prior notice.

Operation Instructions – Beer Dispensers

For sanitation purposes, it may be necessary to seal the base of the cabinet to the floor. This can be accomplished by laying a bead of silicone sealant between the base of the cabinet and the floor as shown by the figure below.

When sealing the cabinet to the floor, make sure that the louvered front grill plate can still be removed for condenser maintenance and cleaning

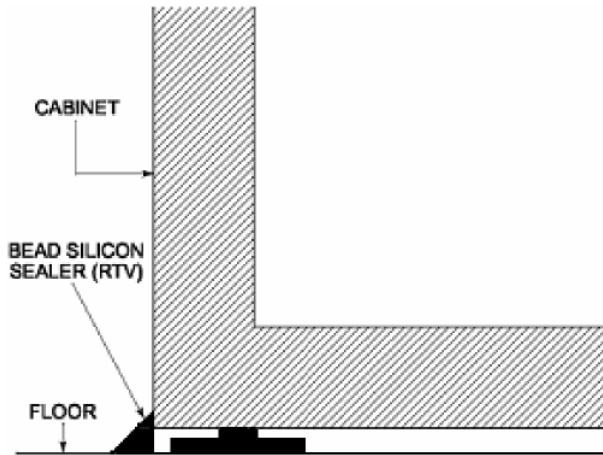

Cleaning the Cabinet

Use a mild detergent and water to clean the inside and outside of the cabinet. Dry thoroughly. Never use a scouring pad or abrasive cleanser.

NOTE: An industrial strength, commercial cleaner can be used to clean the outside of painted cabinets.

Cleaning the Condenser

Use a long handled, stiff brush to clean the dirt from the front surface of the condenser. Keeping the condenser free from dust and dirt will ensure efficient operation.

CAUTION: Do not bend the fins while brushing the front of the condenser.

Temperature Control

An adjustable temperature control is located inside the cabinet on the evaporator fan panel assembly. Approximate temperature operating range: 32° F. minimum and 42° F. maximum. Make adjustments as shown to attain the desired temperature.

- **Colder Temperatures:** Turn the adjusting screw clockwise (to the right).
- **Warmer Temperatures:** Turn the adjusting screw counterclockwise (to the left).
- **Temperature Control "OFF":** Turn the adjusting screw completely counterclockwise to the "O" position until a click is noted.

The condenser fan and the evaporator fan motor turns off and on with the compressor.

Avoiding Stainless Steel Corrosion

Corrosion can be prevented by following product cautions, cleaning instructions and avoiding use of certain chemicals or objects which will cause stainless steel corrosion.

STAINLESS STEEL ENEMY

- Steel wool or steel scouring pads
- Cherry/Orange/Olive juice
- Chlorine Bleach
- Sharp Objects

HOME TAPPED CABINET

INSTALLING DISPENSING HEAD AND FAUCET

BEFORE YOU BEGIN

Wash tapping devices thoroughly. Flush beer and faucet lines and tapping device (keg coupler) with fresh water

- 1) Apply silicone around the base of the dispensing head to seal it to the top. Align the dispensing head over the mounting holes on the cabinet top and secure using screws.

Wipe off excess silicone to complete the seal.

- 2) Attach faucet to dispensing head using spanner wrench to tighten coupling. Attach faucet handle to the faucet.

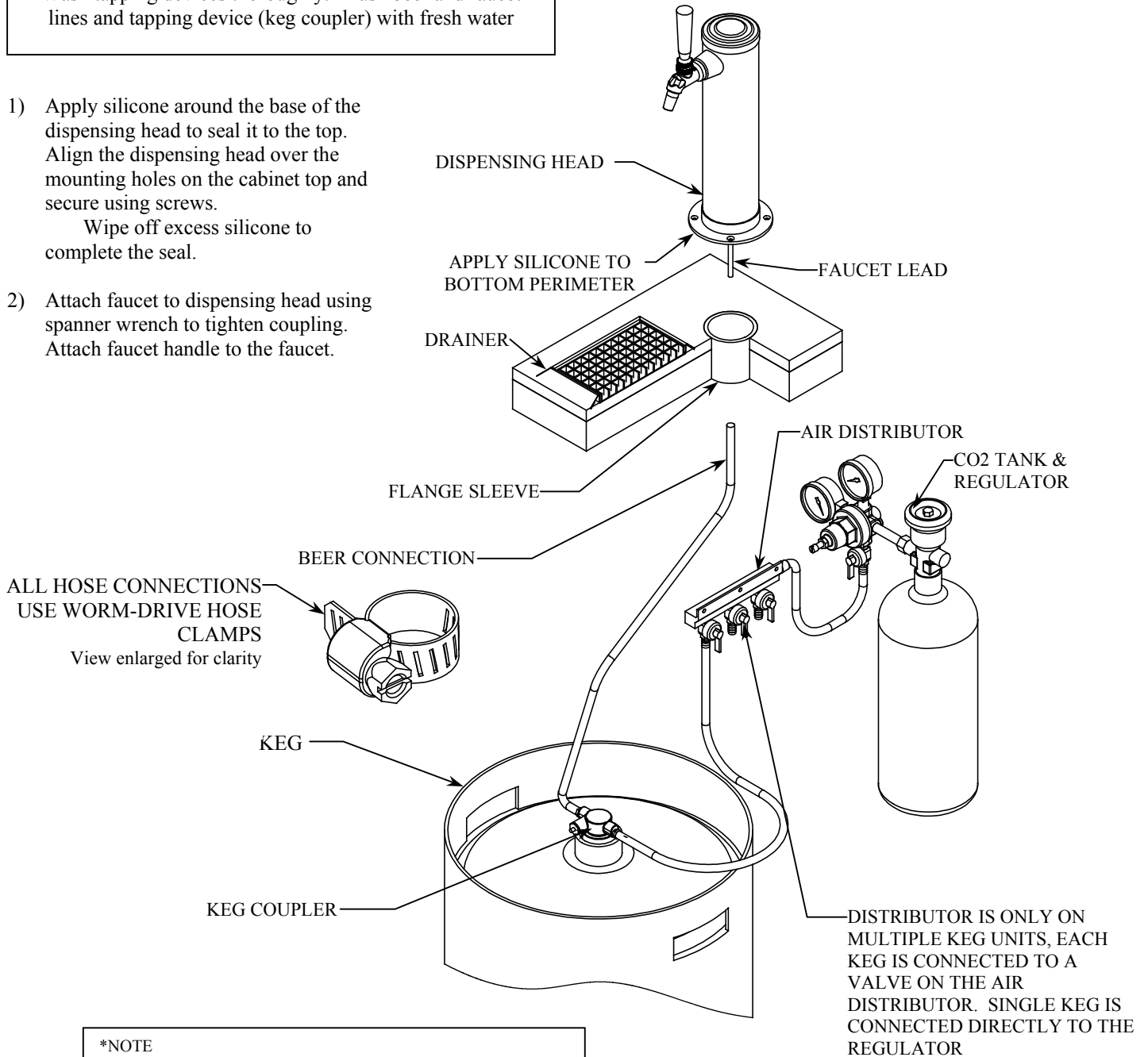

***NOTE**
Image does not accurately reflect positions of the different elements within the unit. Positions and hose lengths shown are to clearly illustrate proper connection methods only.



Perlick is committed to continuous improvement. Therefore, we reserve the right to change specifications without prior notice.

Installation and Tapping – Beer Dispensers

Connecting the Keg Coupler (when Supplied by Perlick)

- Place one brown leather washer into black beer line connector hose on hex nut side. Screw connector to stainless steel beverage line on faucet standard. Tighten with a wrench, but do not over tighten.
- Make sure lever handle on the keg coupler is in the **UP** (untapped) position. Place one brown leather washer into wing nut end of black beer line connector hose and thread onto top of keg coupler. Hand tighten.
- Place clamp on one end of red air line. Push end over air valve located inside cabinet. Tighten clamp with screwdriver. Turn shut-off valve to **OFF** (horizontal) position.
- Place clamp on the other end of red air line and push over tailpiece on coupler. Tighten clamp with screwdriver.

CAUTION: Do not use keg coupler as a handle to lift keg.

Tapping a Single Valve Keg (Sankey):



Single Valve Keg Coupler

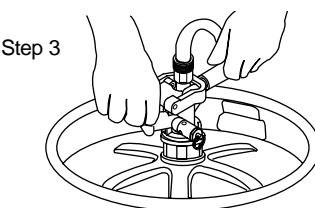
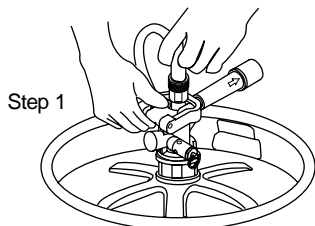

Step 2

Step 3

- Be sure beer faucet is in closed position.
- Align keg lugs with lug openings on bottom of coupler.
- Turn clockwise $\frac{1}{4}$ turn. Pull handle out and down. Keg is now tapped.
- Open shut-off valve on air divider located inside of the cabinet.

Important: Be sure to close this valve when untapping keg.

Connecting the Regulator to the CO₂ Cylinder

- Remove blue plug from regulator fitting. (Note: Do not remove the carbonic washer).
- Screw regulator onto gas cylinder valve. Tighten with wrench until vertically straight. Be sure that shut-off valve (**black lever**) on regulator is in the **OFF (horizontal)** position.
- Place a screw clamp over end of red air line and push onto regulator tailpiece. Tighten clamp with a screwdriver.

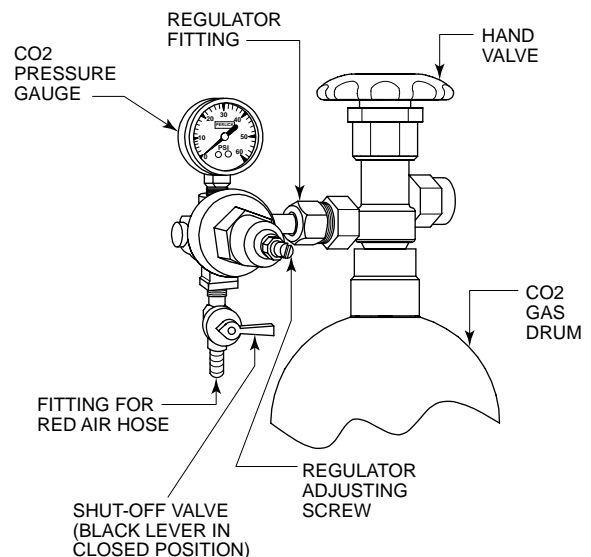

Adjusting the CO₂ Gas Flow

- Turn regulator adjusting screw counterclockwise until it turns freely.
- Turn hand valve counterclockwise on CO₂ cylinder to the fully open position.
- Turn regulator adjusting screw clockwise until desired pressure is reached (approximately 12-15 lbs.). Tighten stop nut on adjusting screw.
- Open shut-off valve on bottom of regulator.

Installation and Tapping – Beer Dispensers

CO₂ Leak Test

Dilute a small amount of liquid dishwashing soap and rub the soapy mixture around each connection. If bubbles appear, tighten connection.

Replacing CO₂ Gas Cylinder

- Turn CO₂ hand valve clockwise until seated and close shut-off valve on regulator.
- Unscrew regulator from cylinder fitting.
- Replace carbonic washer (Part No. 157F2P), if needed and reattach regulator to filled cylinder.
- Turn CO₂ hand valve counterclockwise until fully open. Turn regulator shut-off valve to open position.
- Adjust CO₂ gas flow as required, turning clockwise for higher pressure.

Failure to heed the warnings on this page could result in personal injury or death.

Beverage systems pressurized with carbon dioxide or nitrogen must be equipped with two safety relief valves; one at the cylinder regulator and the other in the gas line upstream on the product tanks.



Temperature

One of the most common causes of dispensing problems is improper temperature. Draft beer should be stored at a temperature between 32° and 38°. At warmer temperatures, beer will foam.

Proper CO₂ Handling

ALWAYS...

- Connect a regulator (reducing valve) to CO₂ cylinder.
- Secure cylinder in upright position whether in storage or in use.
- Keep cylinder away from heat. Rupture disc vents at 122° F. maximum.
- Ventilate room after high pressure gas leakage.
- Check the last DOT test date on cylinder neck before filling. If more than five years old, the cylinder must be retested to DOT specifications.
- Be sure CO₂ cylinder outlet fitting is free of dust or dirt before attaching regulator.
- Store CO₂ cylinder and regulator assembly upright.
- Allow only properly trained and experienced personnel to handle high pressure gas.

NEVER...

- Connect cylinder directly to a keg without a regulator (reducing valve).
- Drop or throw regulator or CO₂ cylinder.
- Transport CO₂ cylinder in a closed vehicle.
- Apply oil to a regulator.
- Shut off CO₂ cylinder when not in use. You will not save gas by doing so!
- Allow untrained, inexperienced personnel to handle high pressure gas.

At temperatures lower than 30° F., beer will freeze. When beer freezes, the alcohol in the beer may separate and cause the beer to be cloudy with an “off” taste.

HOW TEMPERATURE AFFECTS DRAFT BEER

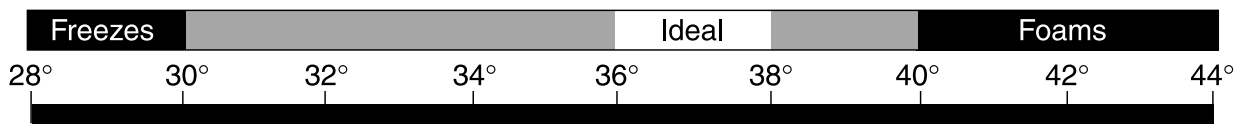

Cleaning the Beer System – Beer Dispensers

The entire beer system, to include the faucet, flexible beer line and tapping devices must be cleaned at regular intervals. We recommend flushing the entire system with fresh water immediately after a keg has been emptied. Once each month the system should be cleaned chemically.

It is recommended that you purchase Perlick's Pump Type Sterilizer, as shown below. It is equipped with an adapter that attaches directly to the faucet shank in lieu of the faucet. It is also available with a slip coupling for those who choose to clean their faucets in place.

Part Nos.	Description
887P	½ Gallon sterilizer w/faucet coupling.
887PSC	½ Gallon sterilizer w/slip coupling.
848A33	33oz Liquid alkaline cleaner.



No. 887P

Cleaning the draft beer system will help to eliminate the buildup of the following materials:

- **Bacteria:**

Beer is an excellent food for bacteria (none of which is harmful). Proper conditions may begin the growth of bacteria in draft beer and on the beer faucet. By regular cleaning, we prevent this bacterial buildup and maintain the quality of the draft beer. Greenish or

yellowish colored material on the faucet may indicate bacterial growth.

- **Yeast:**

All domestic draft beers contain a small amount of yeast which remains in the beer from the fermentation process. When the temperature of draft beer exceeds 50° a process of secondary fermentation may take place. The beer faucet may exhibit a white colored substance (yeast build up) if not cleaned on a regular basis.

- **Beer Stone:**

All beer contains calcium which is present from the grains used in the brewing process. It is an important natural material in draft systems in that as it oxidizes it coats the internal parts of the beer lines and equipment. This thin coat of beer stone helps prevent the beer from picking up strong metallic or plastic flavors as it flows through the system. The beer stone will continue to build if the system is not cleaned properly or regularly and can cause drawing problems if it begins to flake off. Beer stone is present if one can see a brownish color on the faucet or inner wall of the beer line, or tobacco-like flakes in the beer.

Trouble Shooting – Beer Dispensers

Beer Service Problems

■ Wild Beer:

Dispensed beer has either too much foam or is all foam.

CAUSES:

- Beer has been dispensed improperly.

Solution: See pouring instructions on page 8.

- Regulator pressure is set too high.
- Warm keg temperature.

Solution: Keg must be colder than 40°. Target temperature is between 36° and 38° F.

- Cabinet door is opened and closed frequently and temperature is warmer than 38° F.

Solution: Adjust temperature to between 36° and 38° F.

- Kinks, dents or obstructions in the line.
- Using oddly shaped glasses. Frosted, waxed or styrofoam containers may cause foaming.
- Dispenser has been turned off for a long period of time.
- Faucet is bad, dirty or in a worn condition.
- Regulator malfunction.

■ Flat Beer:

Foamy head disappears quickly; beer lacks brewery fresh flavor.

CAUSES:

- Dirty glassware.
- CO₂ pressure is too low, due to leak or pressure setting.
- CO₂ is turned off at night.
- Cooler is too cold.
- CO₂ leak or defective (sticking) check valve.
- Sluggish CO₂ regulator.

■ Cloudy Beer:

Beer in glass appears hazy, not clear.

CAUSES:

- Dirty glass.
- Dirty faucet or beer line.
- Frozen or nearly frozen beer.
- Old beer.
- Beer that has not been refrigerated for a long period of time.

Beer and CO₂ Facts

Keg Size	No. of Gallons	No. of Oz.	No. of Cases	No. of 12Oz. Servings	Full Keg Weight
Quarter	7¾	992	3.445	105	87 lbs.
Half	15½	1,984	6.889	210	161 lbs.

- Beer foam is 25% liquid beer and 75% CO₂ gas. Don't waste it!
- Most people prefer beer stored at 38° F.
- Beer lines and faucets require regular cleaning (see cleaning instructions on page 7).
- A fully-charged 4.2 lb. CO₂ cylinder will dispense approximately 5½ to 6½ half barrels.
- CO₂ gas gives beer its sparkling effervescence. It also gives beer its creamy head of foam.



Door Switching Instructions – Beer Dispensers

Tools Required

- Phillips Screwdriver.
- #4 Allen Wrench.
- Flathead Screwdriver or Putty Knife

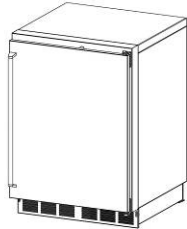

Right Hinged Door
(as shipped from factory)

STEP 8:

Re-insert bottom hinge pin.

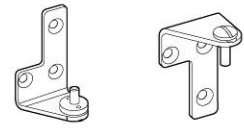

Bottom Hinge Bracket Top Hinge Bracket

Operations to Perform on Door

Operations to Perform on Cabinet

STEP 1:

Remove top hinge pin from assembly.



STEP 2:

Carefully lift and tilt out door assembly from the unit and set aside.

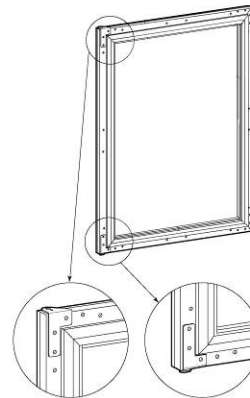

Step #10

Step #9

STEP 3:

Remove bottom hinge pin. Remove top and bottom hinge brackets from the unit.

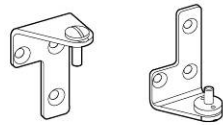

Top Hinge Bracket Bottom Hinge Bracket

STEP 4:

Remove hinge bushing from bottom hinge bracket and assemble to top hinge bracket.



Hinge Bushing

STEP 5:

Taking care not to scratch the surface, remove hole plugs from the left hinge holes.

STEP 6:

Insert hole plugs into vacant right hinge holes

STEP 7:

Re-assemble hinge brackets to unit. Bottom right bracket is assembled as the top left bracket. Top right bracket is assembled as the bottom left bracket.

STEP 9:

Remove bottom door hinge bracket from door assembly and remove door hinge bushing from bracket. Re-assemble door hinge bracket to previous position, without bushing.

STEP 10:

Remove top door hinge bracket from door assembly and assemble door hinge bushing from STEP 11 to bracket. Re-assemble door hinge bracket to previous position with bushing attached.

STEP 11:

What was the door top is now the door bottom. Carefully lift the door onto the hinge brackets of the cabinet. The two hinge bushings should meet. Reinsert the top hinge pin to complete the door switching operation.

Tap Mounting Hole Location – Beer Dispensers

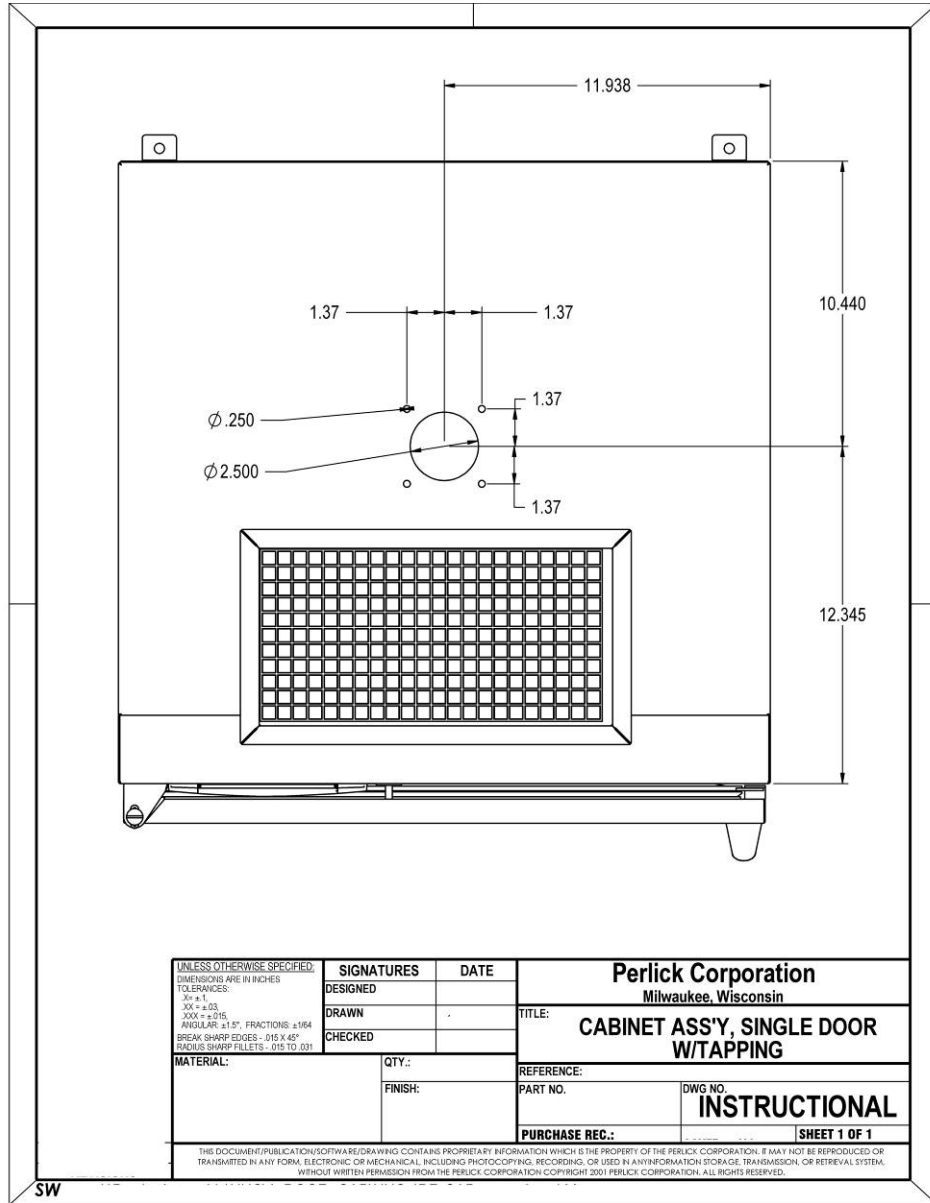

Perlick is committed to continuous improvement. Therefore, we reserve the right to change specifications without prior notice.

Pouring a Perfect Glass of Beer – Beer Dispensers



STEP 1

Start with a clean glass. Place the glass at a 45° angle, one inch below faucet. Do not let the glass touch the faucet. Open the faucet all the way.

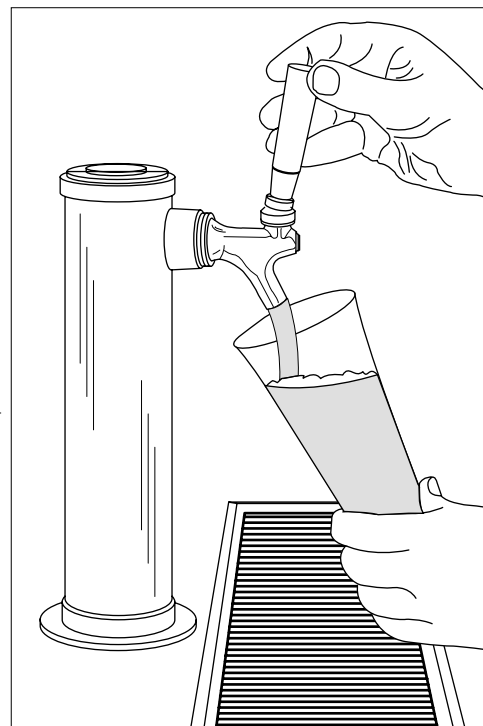

STEP 2

After the glass has reached half full, gradually bring the glass to the upright position

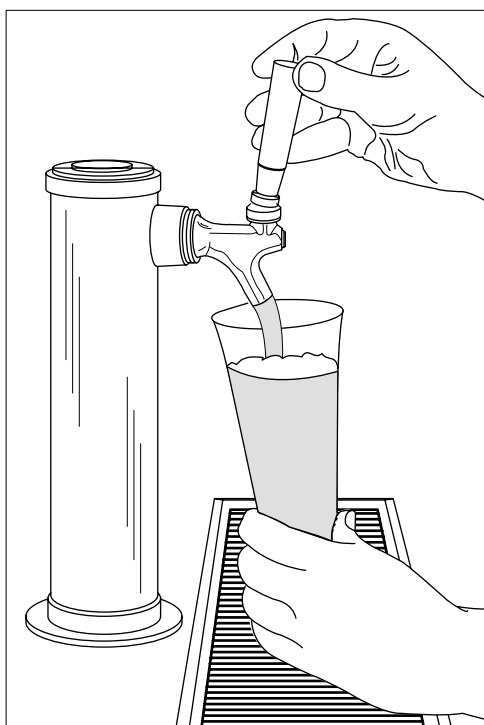

STEP 3

Let the remaining beer run straight down the middle of the glass. This ensures proper release of CO₂ by producing a ¾" to 1" foam head.



STEP 4

Close the faucet quickly and completely.

ITEM	NO. REQ'D	NAME & SIZE	MATERIAL	CATALOG NO.	PART NO.	DRAWING NO.	PATTERN NO.	ROUGH WT.	PURCHAS' RECORD
①	1	TAG	NOTED		43020A2	43020 SHEET 2			X
○									

MATERIAL: STOCK NO.4155, 9-MIL WHITE VALERON W/O ADHESIVE

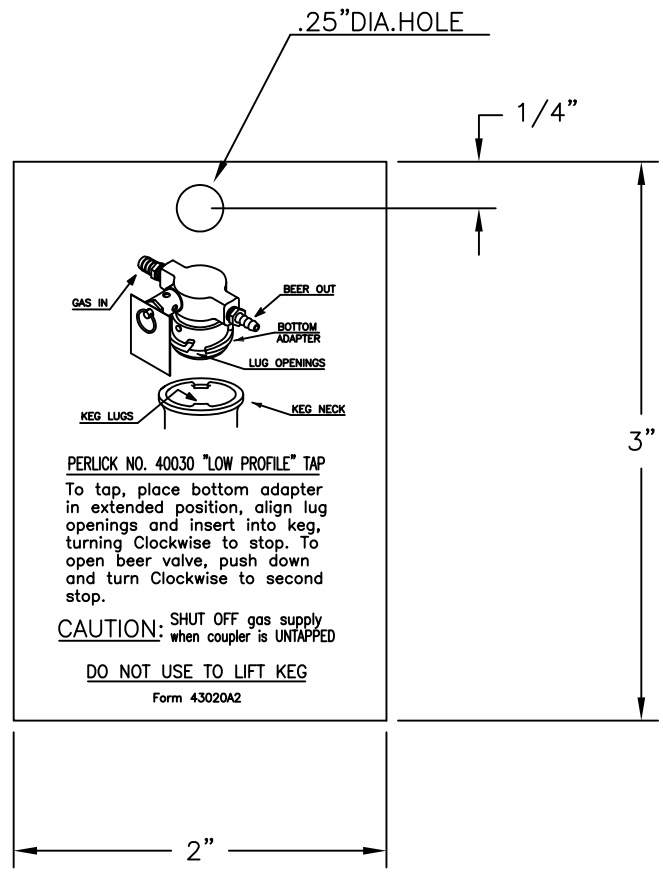

REF. REPLACES 43020A1

TOLERANCES UNLESS OTHERWISE SPECIFIED
 2-PLACE DECIMAL DIMENSIONS = ±.0625" DIMENSIONS ARE IN INCHES

PERLICK CORPORATION MILWAUKEE, WI. .TAG	SCALE <u> </u> FULL SIZE DR. <u>MS</u> DATI <u>8-15-02</u> CHK'D <u> </u> DATE <u> </u> APP'D <u> </u> DATE <u> </u>
---	--

FOR MK20 LOW PROFILE COUPLER NO. 40030	ORDER NO. _____ PRINTED _____
--	----------------------------------

REVISED TAP PICTURE TO BE W/O TOP CAP.
 A 11-21-02
 REVISIONS

THIS DOCUMENT/PUBLICATION/SOFTWARE/DRAWING CONTAINS PROPRIETARY INFORMATION WHICH IS THE PROPERTY OF THE PERLICK CORP. IT MAY NOT BE REPRODUCED OR TRANSMITTED IN ANY FORM, ELECTRONIC OR MECHANICAL, INCLUDING PHOTOCOPYING, RECORDING, OR USED IN ANY INFORMATION STORAGE, TRANSMISSION, OR RETRIEVAL SYSTEM, WITHOUT WRITTEN PERMISSION FROM PERLICK CORP.

43020

SHEET 2 OF 2

Keg Capacity and Location – Beer Dispensers

Single-door Unit

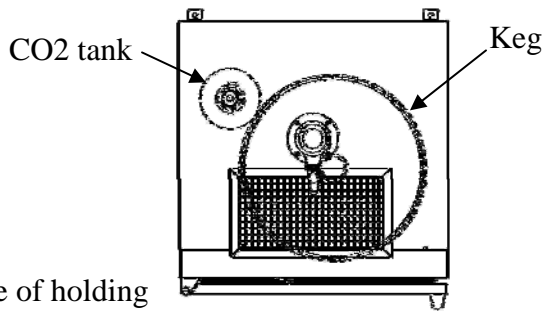

Capable of holding
either (1) 1/4 barrel
Or (2) 1/6 barrels
Positioned as shown

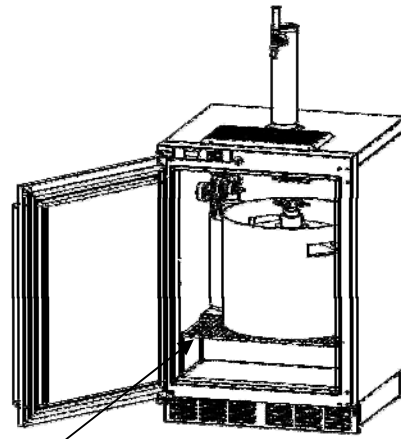
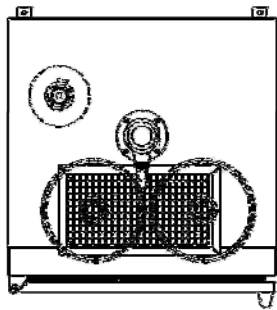

For holding a 1/4 barrel in the first
compartment, the bottom shelf is
always need

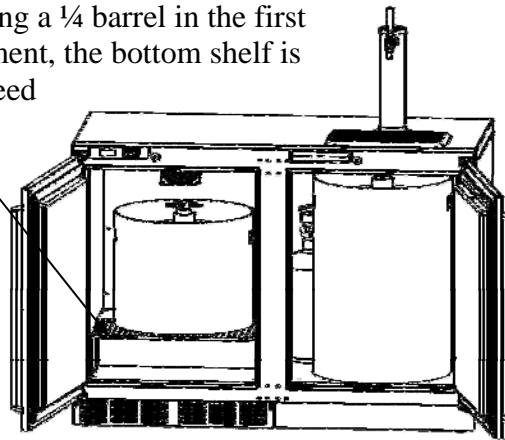

Two-door Unit

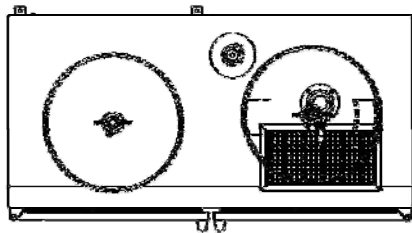

Capable of holding
either (1) 1/4 barrel
Or (2) 1/6 barrels in
the first
compartment
Positioned as shown

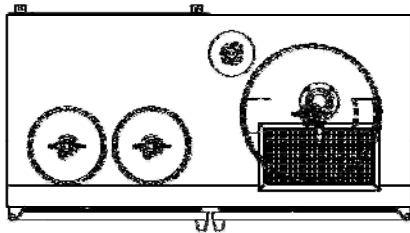

Second compartment can hold up to
(1) 1/2 barrel, or (1) 1/4 barrel, or (3)
1/6 barrels. Shelving can be provided
in the first compartment if desired

